

# A SLURRY SEAL

## WHERE CAN SLURRY SEAL CAN BE APPLIED?

- City Roads
- Highways
- Motorways
- Bridge decks
- Parking Lots
- Airports

## HOW DOES SLURRY SEAL IS APPLIED?

Slurry Seal is applied with specially designed machinery; either truck mounted or attached to a tractor. The specially designed machinery will provide a homogenous mixture that is prescribed by a mix design of a Slurry Surfacing Laboratory.

The mixture prepared, mixed by a pug mill at the machinery and delivered to a spreader box attached behind the machinery. The material is spread on pavement continuously at one step with the movement of the vehicle ahead. The new pavement shall be opened to slow traffic within few hours after the application.

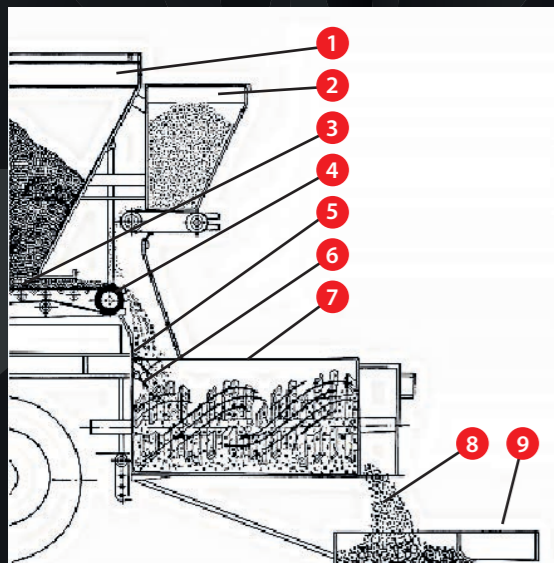

- 1- Aggregate Bin
- 2- Filler Bin
- 3- Aggregate Flow Gate
- 4- Aggregate Conveyor Belt
- 5- Emulsion Injector
- 6- Water Injector
- 7- Pugmill
- 8- Spreader Box
- 9- Slurry

**ASTEK** ASTEK COATING AND ASPHALT TECHNOLOGIES. LTD.

İçaçan Sok 3/2 Gaziosmanpaşa, 06700 Ankara - TURKEY

+90 (312) 467 85 15 +90 (312) 467 85 17 info@asfaltkaplama.com

The slurry seal consists with a homogenous mixture of an approved emulsified asphalt, crushed aggregate, water, and additives, proportioned, mixed and uniformly applied over a properly prepared surface by specially designed machinery and skilled ASTEK personnel.

The completed slurry seal shall leave a homogeneous, water and skid resistant surface. The high amount of bitumen will yield a properly adhered sealing with a long lasting service and protection for the pavement.

## TWO MAIN GOALS TO APPLY SLURRY SEAL:

### Preventive:

To protect the pavement properties and prolong the service life of the pavement.

### Corrective:

To bring back the properties of existing problem surfaces. To seal and protect deteriorated and raveled surface against further oxidation and water penetration that may trigger the freeze and thaw effect.



## VERSATILE SLURRY SEAL SYSTEM WILL PROVIDE ;

- A bituminous pavement surface as required
- Fills up small cracks and gets rid of the pavement imperfections
- Economical application
- Non bleeding, weather resistant strong and durable sealing
- A bold and uniform black appearing pavement
- Very high skid resistant surface, providing safe driving conditions.
- Very versatile pavement system that can fulfill various requirements
- Extension of the pavement life while keeping its properties.
- A fast application allows the pavement to re open to traffic in a few hours.
- Provides safe driving conditions without the loss of aggregate.
- Application to old or new pavement without need for rolling and compaction.
- Weather proof membrane like surface with is high amount of bitumen consistency
- 3 designed thicknesses, based on traffic and surface requirements.
- A special design can be used to fulfill all the toughest requirements.

## AGGREGATE GRADATIONS

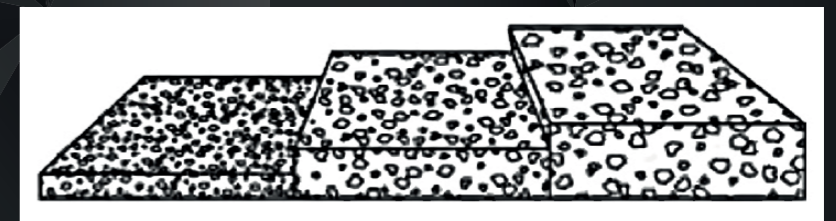

**TYPE 1**  
4-5 mm

**TYPE 2**  
6-7 mm

**TYPE 3**  
8-9,5 mm